

MANUAL GRAVITY SPRAY GUN

NT-104

OPERATION MANUAL



NT10-104-MP-G16

NT10-104-MP-G18



info@onetech-tools.com



www.onetech-tools.com



ONETECH

Tools

ATTENTION! PLEASE READ THIS MANUAL BEFORE USING THE SPRAY GUN (TOOL).

IMPROPER TOOL USE MAY CAUSE INJURY AND/OR PROPERTY DAMAGE!

ONLY QUALIFIED AND SPECIALLY TRAINED PERSONNEL FAMILIED WITH THESE INSTRUCTIONS IS ALLOWED TO USE AND MAINTENANCE OF THE TOOL.

This manual contains description, safety rules and all the information necessary for the correct use of the spray gun.

The safety advice given in this manual is in addition to and does not replace the general safety regulations applicable in the region where the tool is used.

- Sprayed materials (paints, solvents, etc.) can be harmful to health. Always read all labels, safety data sheets and follow all the recommendations for the material before spraying. In case of doubts, contact your material supplier. The use of respiratory protective equipment is always recommended.
- Always wear eye protection when spraying or cleaning the spray gun.
- Gloves must be worn during spraying or cleaning the equipment.
- Static electricity can be generated by fluid and/or air passing through hoses, by the spraying process and by cleaning non-conductive parts with cloths. To prevent ignition sources from static discharges, earth continuity must be maintained to the spray gun and other metallic equipment used. It is essential to use conductive air and/or fluid hoses.
- Sparks, open flames or hot surfaces can create a fire or explosion.



GENERAL RULES OF OPERATION

- When working with the tool always use personal protective equipment appropriate for the type of work performed (goggles, impact resistant glasses, hand protection, body, etc.);
- The employee's appearance must comply with safety requirements;
- Use spray gun only for its intended purpose;
- Observe grounding rules in the workplace;
- To ensure maximum performance and durability of the tool, the working pressure of the compressed air must match the spray technology;
- High noise levels can cause hearing loss. Timely maintenance will help to avoid noise levels increase;
- The flow of compressed air can cause serious injury. Never direct airflow towards yourself or others. Do not use compressed air to clean clothes;
- Before starting work, check the compressed air supply hose for damage, wear or other defects. Replace immediately if found;
- Check screw connections before starting work. Tighten if necessary;
- Do not carry the tool by the compressed air supply hose;
- Always disconnect the tool from the compressed air line before performing maintenance;
- Use materials and solvents that are compatible with the spray gun parts. Do not use solvents or products containing acids;
- Avoid prolonged exposure to solvents on non-metallic parts of the spray gun.
- Flush spray gun before starting use, before changing materials and at the end of work. Do not use methylene chloride 1,1,1-trichloroethane for flushing. These solvents can chemically react with aluminum gun parts.

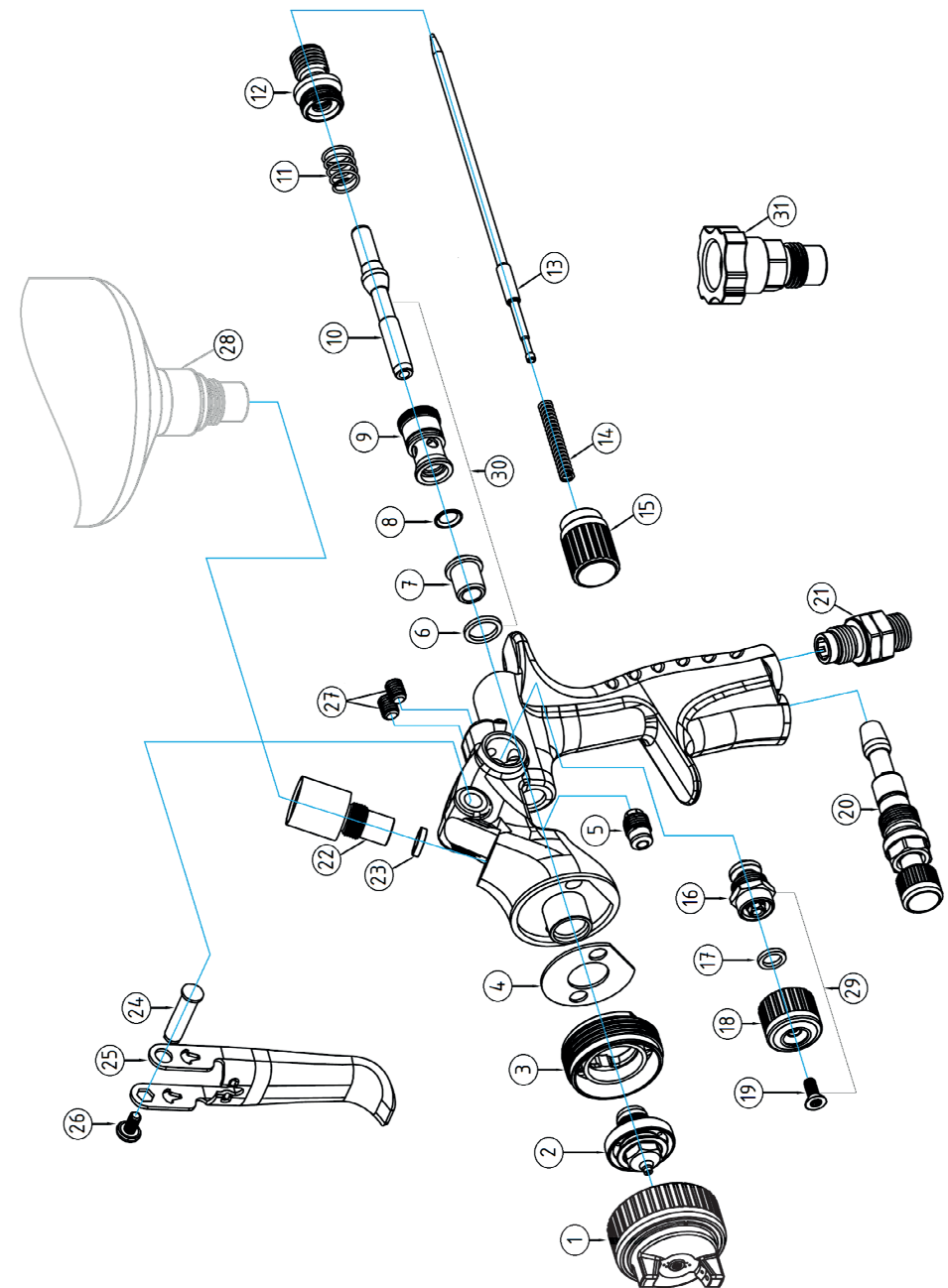

REPLACEMENT PARTS

No.	Description	Part No.	No.	Description	Part No.
1.	Air cap MP	NT10S-414	16.	Fan adjusting set	–
2.	Fluid nozzle 1.6 (for MP)	NT10S-415	17.	Sealing ring	–
	Fluid nozzle 1.8 (for MP)	NT10S-416	18.	Fan adjusting knob	–
3.	Air distribution ring	NT10S-417	19.	Screw (M4)	–
4.	Gasket	NT10S-418	20.	Air adj. set	NT10S-434
5.	Needle packing nut	NT10S-419	21.	Air inlet joint (360°)	NT10S-435
6.	Gasket	–	22.	Fluid inlet joint	NT10S-436
7.	Valve sleeve	–	23.	Gasket	NT10S-437
8.	Gasket	–	24.	Trigger pin	NT10S-438
9.	Air valve sleeve	–	25.	Trigger	NT10S-439
10.	Valve rode	–	26.	Screw (M4)	NT10S-440
11.	Air valve spring	NT10S-425	27.	Screw (M3)	NT10S-441
12.	Fluid needle seat	NT10S-426	28.	Fluid cap 600 ml (not included)	NT05A-0073
13.	Fluid needle 1.6/1.8 (for MP)	NT10S-427	29.	Pattern adjusting set (inc. 16, 17, 18, 19)	NT10S-444
14.	Fluid needle spring	NT10S-428	30.	Air valve set (inc. 6, 7, 8, 9, 10)	NT10S-445
15.	Fluid adjusting knob	NT10S-429	31.	Adapter EPS	NT05-EPS

Service Kit (included)

	NT10S-443	<ol style="list-style-type: none"> Hex wrench (for removing the screws on the trigger); Wrench 12 mm (for removing the nozzle); Updated brush; Small wrench 6 mm (for removing needle packing nut); Quick coupling adapter; Plastic gasket for sealing (insert it into the air connector); Filter (NT01G-0001); Gaskets (3 pcs.) for gun head (NT10S-418).
--	-----------	--

TOOLS AND ACCESSORIES

	NT05-EPS-600	Efficient painting system cup, 600 ml.
	NT05-RP-003-G	Air pressure regulator with gauge: <ul style="list-style-type: none"> – material: tempered glass, brass, SST, iron, plastic; – pressure range: 0-10 Bar; – gauge size: Ø 33 mm.

PURPOSE

Pneumatic gravity spray gun is designed to apply liquid and low-viscosity materials (varnishes, enamels, primers, etc.) to the surface to be treated manually, by pneumatic spraying.

These spray guns are suitable for use with both water and solvent based coating materials. These guns are not designed for use with highly corrosive and/or abrasive materials and if used with such materials it must be expected that the need for parts cleaning and/or replacement will be increased. If there is any doubt regarding the suitability of a specific material, contact your ONETECH Distributor or ONETECH team directly.

OPERATING PRINCIPLE

- ✓ The airflow required for spraying is supplied to the spray gun through a suitable air inlet connection.
- ✓ When you press the trigger, the airflow, passing through the corresponding channels in the spray gun body, exits through the holes in the air cap.
- ✓ When exiting through the holes in the air cap, the air stream mixes with the sprayed material, and the additional directional flow breaks the material into small droplets and forms a paint spray.

MAINTENANCE

- ✓ To clean air cap and fluid nozzle, brush exterior with a stiff bristle brush. If necessary to clean cap holes, use a broom straw or toothpick if possible. If a wire or hard instrument is used, extreme care must be used to prevent holes scratching or burring, which may cause a distorted spray pattern.
- ✓ To clean fluid passages, remove excess material from cup, then flush with solvent. Wipe the gun exterior with a dampened cloth. Never completely immerse the tool into any solvent or cleaning solutions, as this is detrimental to the lubricants and spray gun life.

STORAGE

- Avoid storing the instrument in high humidity conditions.
- Lubricate the tool before long-term storage (see MAINTENANCE).

DISPOSAL

- When disposing of the tool or individual components, observe the local regulations in force in the region where the equipment is used.

THE AIR SUPPLY SYSTEM

- Always use clean, dry air.
- Recommended diameter of the compressed air hose ID Ø3/8" (≈ 9 mm).
- Maintain the necessary supply of compressed air in the airline for trouble-free and optimal tool performance.

EXAMPLE OF AIR SUPPLY SYSTEM

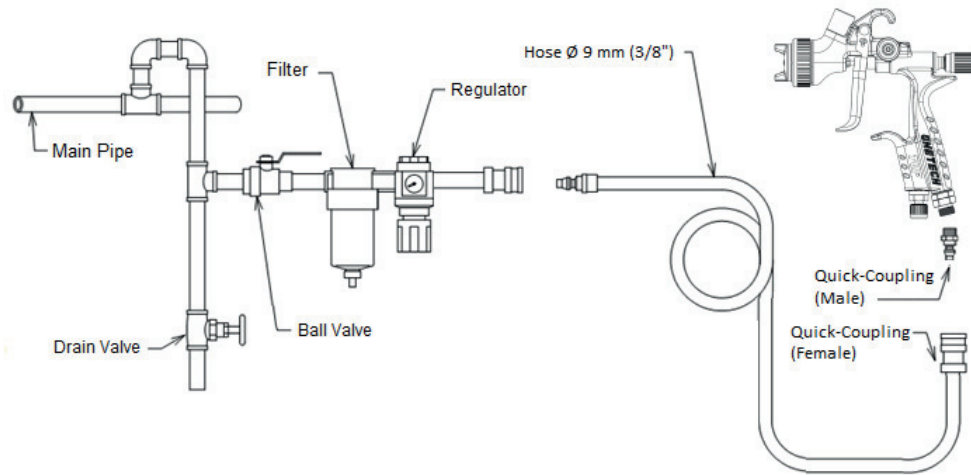

TECHNICAL SPECIFICATION

Model	Nozzle, mm	Air cap	Air pressure (recommend.), bar	Air consumption, l/min	Material consumption, ml/min	Spray width*, mm	Weight**, g
NT10-104-MP-G16	1.6	MP	2.0	290	255	260 – 300*	476**
NT10-104-MP-G18	1.8				290		

* – spraying distance 170 – 200 mm, fluid viscosity – 20±1 seconds.

** - without fluid cup.

Material inlet thread	Air inlet thread
M16x1.5 (F)	G 1/4" (M)

TROUBLESHOOTING GUIDE



FLUTTERING

Possible Cause	Solution
Insufficient material in cap	Refill material
Dry or worn fluid needle packing set or loose fluid needle packing screw	Lubricate or replace fluid needle packing set or tighten fluid needle packing screw
Loose or damaged fluid nozzle	Tighten or replace fluid nozzle



CRESCENT

Possible Cause	Solution
Material store-up on air cap	Clean air cap with proper objects



HEAVY TOP OR BOTTOM

Possible Cause	Solution
Material store-up on air cap	Clean or replace air cap
Dirty or damaged fluid nozzle	Clean or replace fluid nozzle



SPLIT

Possible Cause	Solution
Material too thin or too much	Increase material viscosity
Atomizing air pressure too high	Reduce air pressure



HEAVY CENTER

Possible Cause	Solution
Material too thick or too much	Reduce material viscosity
Atomizing air pressure too low	Increase air pressure

MATERIAL DRIPS FROM FLUID NOZZLE

Possible Cause	Solution
Obstructions between fluid nozzle and fluid needle	Clean fluid nozzle and fluid needle in thinner
Worn fluid nozzle or needle	Replace part

MATERIAL LEAKS FROM NEEDLE PACKING SCREW

Possible Cause	Solution
Loose fluid needle packing screw	Tighten fluid needle packing screw, check fluid needle for free movement